

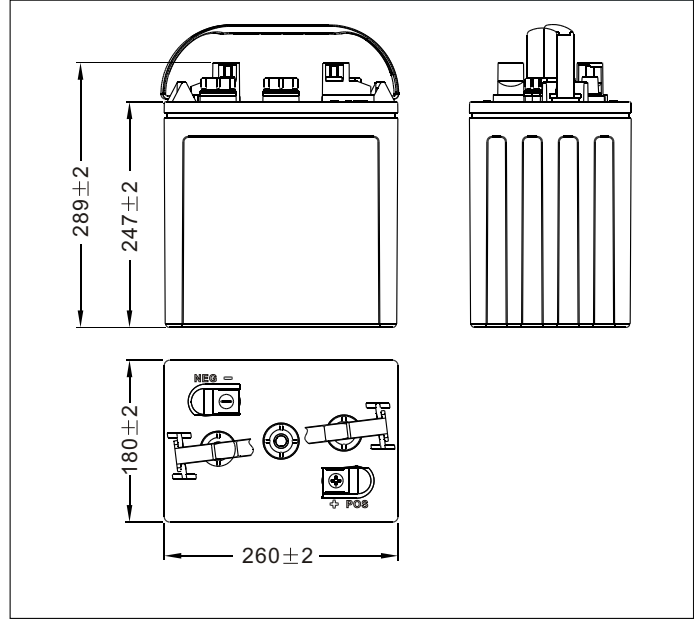

# DT606 [6V210Ah] GOLF CART BATTERY



## Dimensions (mm)



## Physical Specification (mm)

Nominal Voltage	6V	
Nominal Capacity(20HR)	210Ah	
Nominal Capacity(5HR)	175Ah	
Dimension	Length	260 ± 2mm(10.24inches)
	Width	180 ± 2mm(7.09inches)
	Container Height	247 ± 2mm(9.72inches)
	Total Height(with Terminal)	289 ± 2mm(11.38inches)
Dry Weight	Approx 20.7Kg(45.6lbs)	
Wet Weight	Approx 27.6Kg(60.8lbs)	
Acid	1.280 ± 0.015g/cm <sup>3</sup> ( 25C )	
Standard Terminal	M1	
Hold-Down	/	
Cell plate qty	/	
Case	Cool Gray8C-Material	
Cover	Cool Gray8C-Material	
Handle	Cool Gray8C-Material	

## Standard Terminal (mm)

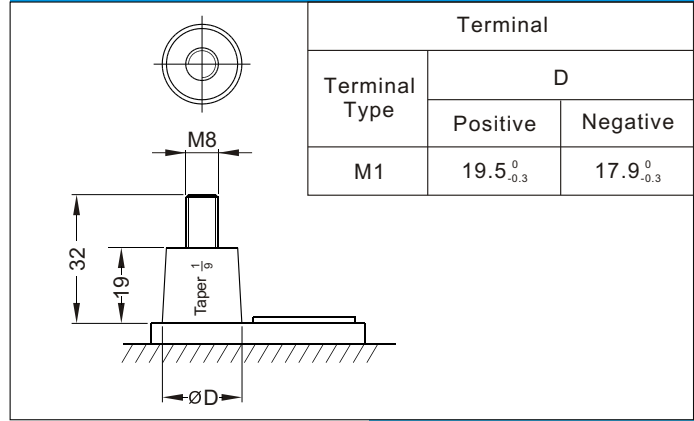

## Discharge Characteristics(25°C,70°F)

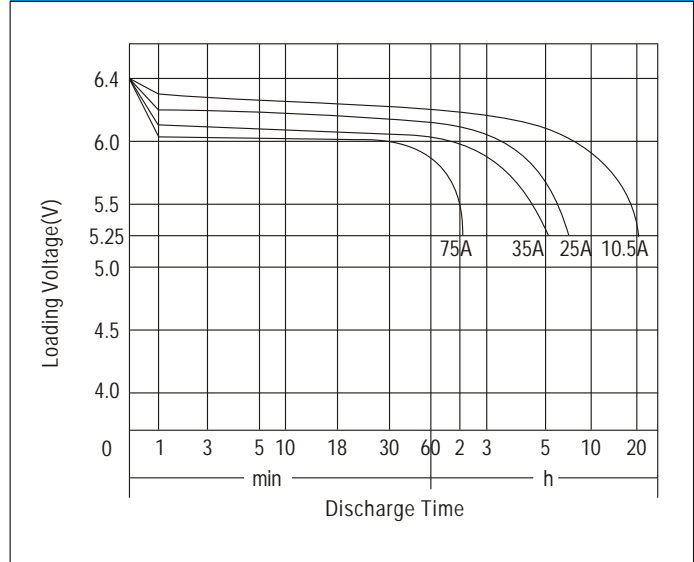

## Electrical Specification

Rated Capacity	20 hour rate(10.5A)	210Ah
	5 hour rate(35.0A)	175Ah
Reserve Capacity	25Amps	380min
Reserve Capacity	75Amps	105min